

CAD FILE:

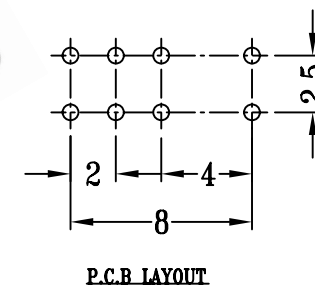
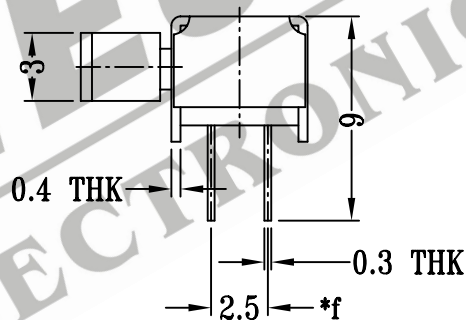
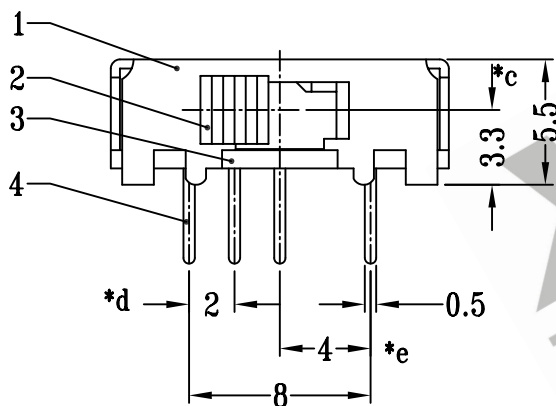
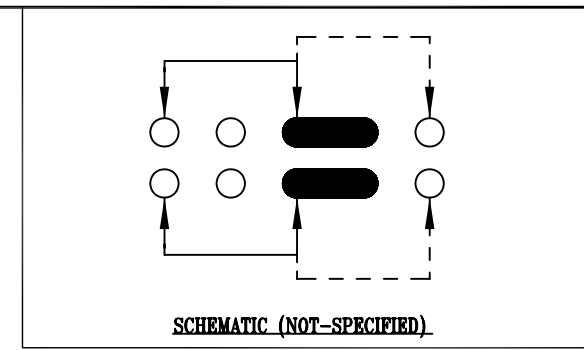
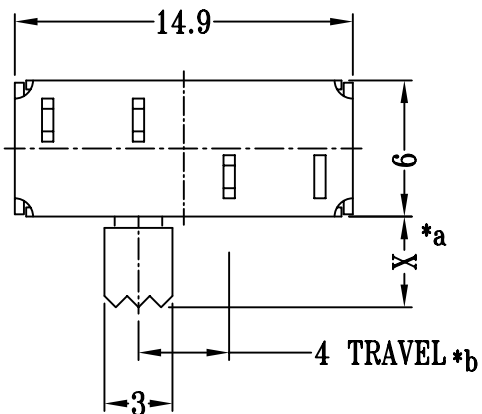

注:带"*"表示关键尺寸(7个)

				TOLERANCE UNLESS SPECIFIED		SHENZHEN XIEJIA ELECTRONICS CO.,LTD.				
				WITHIN: 1.5±0.1mm		ISSUE	DATE	DESCRIPTIONS OF REVISION		APPD.
				OVER : 1.5±0.2mm						
8										
7										
6	SPRING PLATE	STAINLESS STEEL	1	NATURAL						
5	CONTACT CLIP	PBS	2	Ag CLAD						
4	TERMINAL	BRASS STRIP	8	Ag PLATED OVER Ni PLATED	TITLE : HORIZONTAL SLIDE SWITCH		UNIT : mm	DRWG NO.: XJ-DR-SK22H28-00		
3	BASE	PHENOLIC RESIN	1	NATURAL	MODEL: SK-22H28		SCALE: 3:1	DWN.	ZHOUYU	2007-9-5
2	KNOB	POM	1	BLACK				CHK'D	FANGYING	2007-9-5
1	FRAME	STEEL STRIP	1	Ni PLATED				APPD.	KANGXINAN	2007-9-5
NO.	PARTS	MATERIALS	Q'TY	FINISH	ALL MATERIALS MUST BE COMPLIANT TO ROHS					